



AIRCHARGER®

HIGH-FLOW INTAKE KITS

NOT LEGAL FOR SALE OR USE ON ANY POLLUTION CONTROLLED MOTOR VEHICLE IN CALIFORNIA OR STATES ADOPTING CALIFORNIA EMISSION PROCEDURES.
See knfilters.com for CARB status on each part for a specific vehicle

INSTALLATION INSTRUCTIONS

63-1145
HONDA
2019-20 / TALON
1000cc

TOOLS NEEDED:

- 10mm socket
- 13mm socket
- Ratchet
- Extension
- 10mm wrench
- 13mm wrench
- Flat blade Screw driver
- Phillips Screw driver
- 4mm allen key
- Pliers

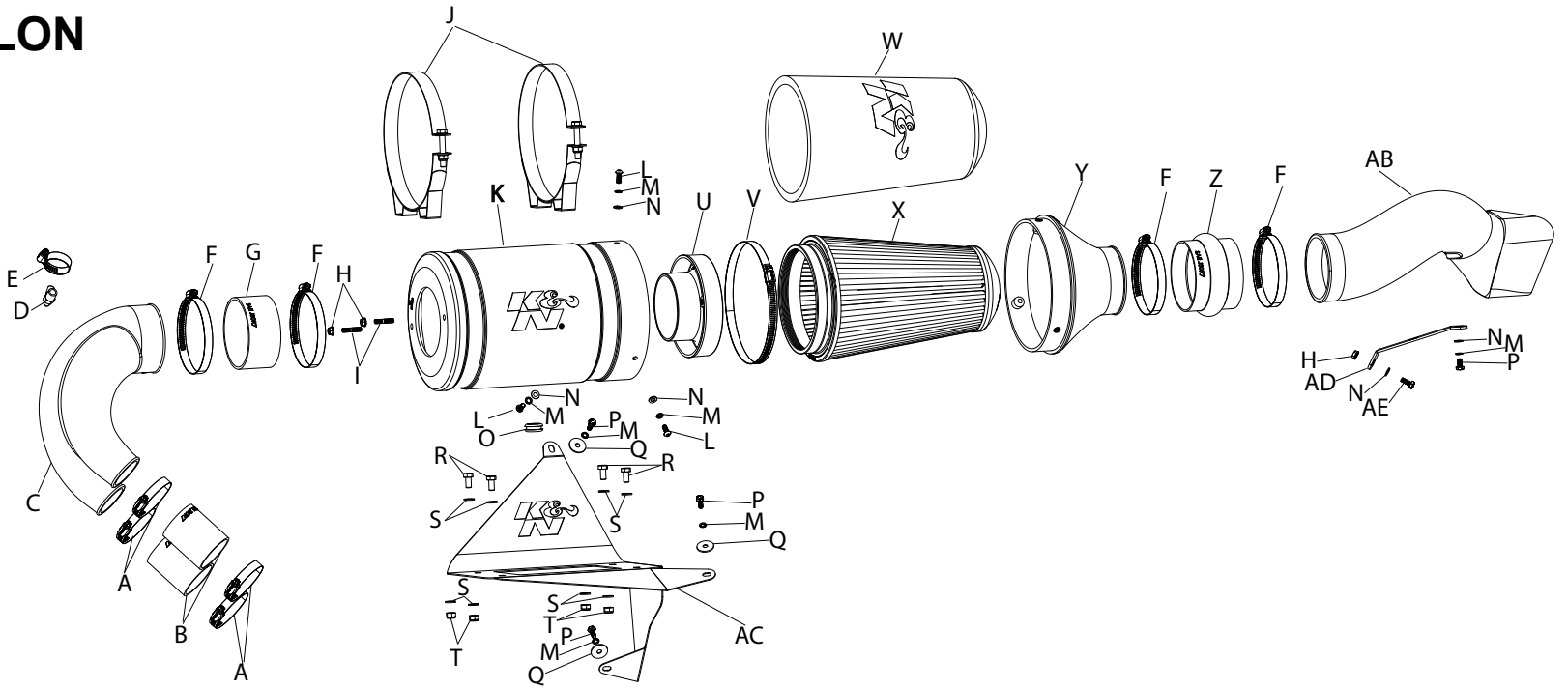

PARTS LIST:

Description	Qty.	Part #	Description	Qty.	Part #	Description	Qty.	Part #
A HOSE CLAMP #36	4	08530	L BOLT; M6 X 1.00 X 16MM	3	07730	W PRE-WRAP; 7-1/2"B	1	973804
B HOSE; 2.25" X 3"	2	5-225	M WASHER; M6 SPLIT LOCK ZINC	7	1-3025	X AIR FILTER	1	RU-5064
C TUBE; AIRCHARGER	1	087495	N WASHER; 6MM FLAT	5	08269	Y LID; UNIVERSAL	1	087326A
D FITTING; VENT, 1/4"NPT	1	08523	O GROMMET; 15/16"OD	1	08100	Z HOSE; HUMP 4"ID X 3"L	1	08418
E HOSE CLAMP #6 MINI	1	08407	P BOLT; M6 X 1.00 X 12MM	4	07727	AB TUBE; FRESH AIR	1	087496
F HOSE CLAMP #64 STAINLESS	4	08645	Q WASHER; 1"D X 1/4" HOLE	3	08160	AC MOUNTING PLATE; MILD STL	1	073313
G HOSE; 4"ID X 2"L	1	08761	R BOLT; 8MM-1.25 X 20MM HEX	4	07787	AD BRACKET; "L"	1	064364
H NUT; M6, HEX, SERRATED	3	444.460.04	S WASHER; 8MM FLAT	8	08272	AE BOLT; 6MM-1.00 X 16MM	1	07812
I STUD; M6-1 X 30 DBL	2	1-107	T NUT; 8MM NYLOCK	4	07502			
J SADDLE CLAMP; 8" DUAL	2	07293	U ADAPTOR; # 454	1	27300			
K CANISTER, LC	1	087328A	V HOSE CLAMP #104	1	08697			

If you need any assistance please call 1-800-858-3333 to speak with a representative in our Customer Service Center before returning the product.

NOTE: FAILURE TO FOLLOW INSTALLATION INSTRUCTIONS AND NOT USING THE PROVIDED HARDWARE MAY DAMAGE THE INTAKE TUBE, THROTTLE BODY AND ENGINE.

TO START:

1. Turn off the ignition and disconnect the negative battery cable.
NOTE: Disconnecting the negative battery cable erases pre-programmed electronic memories. Write down all memory settings before disconnecting the negative battery cable. Some radios will require an anti-theft code to be entered after the battery is reconnected. The anti-theft code is typically supplied with your owner's manual. In the event your vehicles anti-theft code cannot be recovered, contact an authorized dealership to obtain your vehicles anti-theft code.



2. Unlock the two quarter turn fasteners and then remove the air filter access panel.



3. Remove the 12 clips that secure the fresh air duct cover and then remove the cover.



4. Loosen the hose clamp and retaining clips that secure the fresh air intake duct and then remove the duct.



5. Loosen the two hose clamps that secure the intake hose to the throttle bodies.



6. Remove the air filter housing drain hose shown.



7. Remove the three bolts that secure the air filter housing.



8. Remove the bolt that secures the air filter housing bracket to the exhaust.



9. Partially remove the air filter system and then disconnect the inlet air temperature sensor electrical connection. Now remove the air filter assembly completely from the vehicle.



10. Install the two provided canister mounting bracket clamps onto the mounting bracket.



11. Install the bracket assembly into the position and secure with the provided hardware.



12. Install the 90deg vent fitting into the K&N intake tube as shown.



13. Install the two provided couplers onto the throttle bodies as shown and secure with the provided hose clamps.



14. Place the K&N air filter housing into position on the clamps, using the factory inlet air temperature sensor wiring harness as a guide mark the housing for a drill point.



15. Drill an 11/16" id hole at the marked location and install the provided grommet into the housing. **NOTE: The hole should be in the approximate location shown in the photo.**



16. Remove the inlet air temperature sensor from the factory air filter housing and install it into the grommet installed into the K&N housing.



17. Install the K&N intake tube into the couplers at the throttle bodies and secure with the provided hose clamps. Connect the CCV hose to the fitting installed into the K&N intake tube and secure with the provided clamp.



18. Install the two provided studs into the filter adapter as shown.



19. Install the K&N air filter onto the filter adapter and secure with the provided hose clamp, then install the foam filter wrap onto the air filter.



20. Install the filter assembly into the housing and secure with the provided hardware.



21. Install the housing lid and secure with the provided hardware



22. Remove the retaining clips and then remove the fresh air duct seal.



23. Install the K&N air filter assembly along with the provided large hump coupler. Secure the housing with the clamps and secure the coupler with the hose clamps.



24. Reconnect the inlet air temperature sensor electrical connection.



25. Install the smaller hump coupler onto the filter housing inlet and secure with the provided hose clamp.



26. Install the fresh air duct mounting bracket onto the K&N fresh air duct using the provided hardware.



27. Install the fresh air duct into the coupler and then align the bracket, adjust the duct for best fit and then secure with the provided hardware and hose clamps.



28. Reinstall the fresh air intake duct cover and the original mounting clips.



29. Reinstall the air filter access panel and secure with the factory quarter turn fasteners.

30. Reconnect the vehicle's negative battery cable. Double check to make sure everything is tight and properly positioned before starting the vehicle.

31. It will be necessary for all K&N® high flow intake systems to be checked periodically for realignment, clearance and tightening of all connections. Failure to follow the above instructions or proper maintenance may void warranty.

ROAD TESTING:

1. Start the engine with the transmission in neutral or park, and the parking brake engaged. Listen for air leaks or odd noises. For air leaks secure hoses and connections. For odd noises, find cause and repair before proceeding. This kit will function identically to the factory system except for being louder and much more responsive.
2. Test drive the vehicle. Listen for odd noises or rattles and fix as necessary.
3. If road test is fine, you can now enjoy the added power and performance from your kit.
4. K&N Engineering, Inc., requires cleaning the intake system's air filter element every 100,000 miles. When used in dusty or off-road environments, our filters will require cleaning more often. We recommend that you visually inspect your filter once every 25,000 miles to determine if the screen is still visible. When the screen is no longer visible some place on the filter element, it is time to clean it. To clean and re-oil, purchase our filter Recharger® service kit, part number 99-5050 or 99-5000 and follow the easy instructions.

NOT LEGAL FOR SALE OR USE ON ANY POLLUTION CONTROLLED MOTOR VEHICLE IN CALIFORNIA OR STATES ADOPTING CALIFORNIA EMISSION PROCEDURES.

See knfilters.com for CARB status on each part for a specific vehicle

* FREE K&N® decal To register your warranty, please see us online at knfilters.com/register. FREE K&N® decal *